

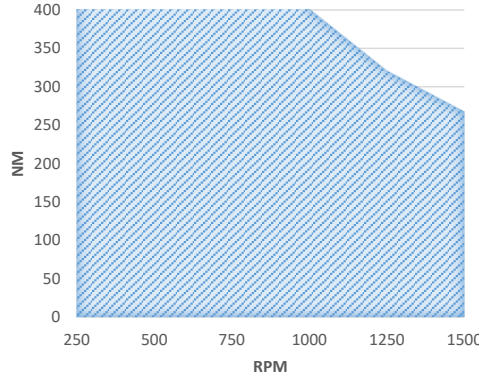

ÖZCIHAN MAKİNA
Özcihan Makina San. ve Tic. Ltd. Şti
www.ozcihan.com.tr



REDÜKTÖRLÜ PTO / PTO REDUCER



ARAÇ MARKASI TRUCK
BRAND

PTO KODU

CTM 221

TEKNİK ÇİZİM / TECHNICAL DRAWING

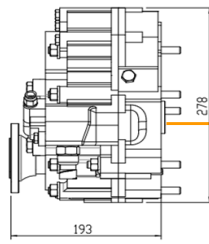
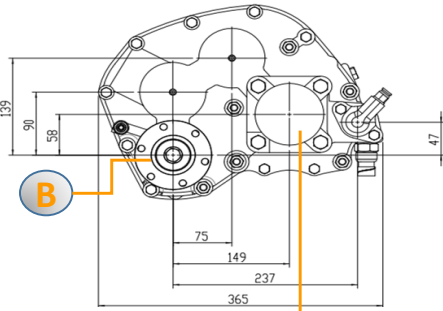

A

B

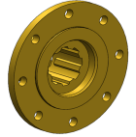
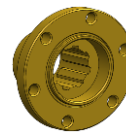
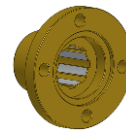

1.12.34
Ø100
8X32X36

1.12.03
Ø100
8X32X36

1.12.36
Ø120
8X32X36

C

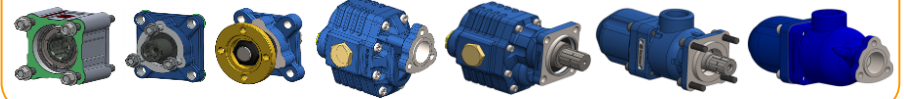
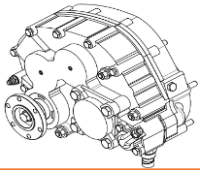

OPSİYONLAR / OPTIONS

A

GİRİŞ (İSTEĞE BAĞLI)

B

ÇIKIŞ (İSTEĞE BAĞLI)

C

ÇIKIŞ ORAN/OUTPUT RATIO : 1-1 (1000 RPM)
TORK/TORQUE : 40 KGM (392 NM) _ GÜÇ /POWER : 38 KW

BAĞLANTI / MOUNTING SIDE

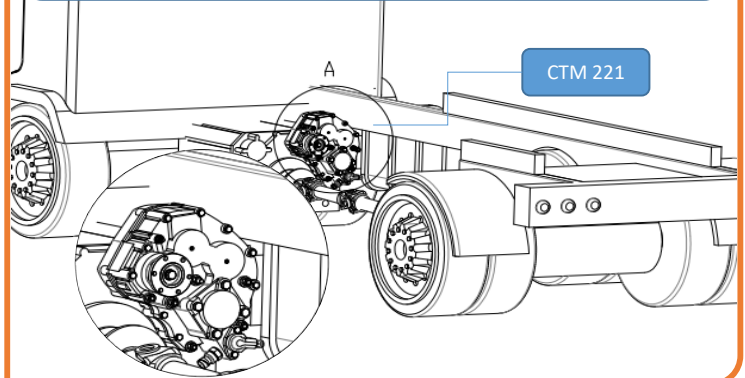

TEKNİK BİLGİLENDİRME / TECHNICAL INFORMATION

B

ÇEVİRME ORANLARI/RATIO: 1-2_1-3,5_1-4,60

(1-2) TORK/TORQUE: 72KGM(705NM) GÜÇ/POWER (1000 DEV/DAK): 75 KW
(1-3,52) TORK/TORQUE: 48KGM(470NM) GÜÇ/POWER (1000 DEV/DAK): 50 KW
(1-4,60) TORK/TORQUE: 39KGM(382NM) GÜÇ/POWER (1000 DEV/DAK): 41 KW

ANA ŞANZİMAN MODELİ

G 60 -6 , G 85-6, G 71-6 , G90-6

DİŞLİ TİPİ
GEAR TYPE

HELİS
HELIX



DÖNÜŞ YÖNÜ
ROTATION SENSE

SOL /
LEFT



AĞIRLIK / WEIGHT
24 KG